

General Description

The AAT3682 is a Lithium-Ion linear battery charger. It is designed for compact portable applications with a single cell battery. The AAT3682 precisely regulates battery charge voltage and charge current, and offers an integrated pass device minimizing the number of external components required.

The AAT3682 charges the battery in three different phases: preconditioning, constant current, and constant voltage. In preconditioning mode, the charge current has two different levels and is controlled by one external pin. Battery charge temperature and charge state are carefully monitored for fault conditions. A battery charge stable monitor output pin is provided to indicate the battery charge status through a display LED or interface to a system controller. The AAT3682 has the sleep mode option for when the input supply is removed. In this mode, it draws only 2.0µA of typical current.

The AAT3682 is available in a 16-pin QFN44 and is specified over the -20°C to 70°C temperature range.

Features

- V_{IN} Range: 4.7V to 6.0V
- Low Quiescent Current, Typically 0.5mA
- 1% Accurate Preset Voltage
- 650mA Charging Current
- Integrated Pass Device
- Battery Temperature Monitoring
- Fast Trickle Charge Option
- Deep Discharge Cell Conditioning
- LED Charge Status Output or System Microcontroller Serial Interface
- Power-on Reset
- Lower Power Sleep Mode
- Status Outputs for LED or System Interface Indicates Charge and Fault Conditions
- Temperature Range: -20°C to 70°C
- 16-Pin QFN44 Package

Applications

- Cellular Telephones
- Digital Still Cameras
- Hand-Held PCs
- MP3 Players
- Personal Data Assistants (PDAs)

Typical Application

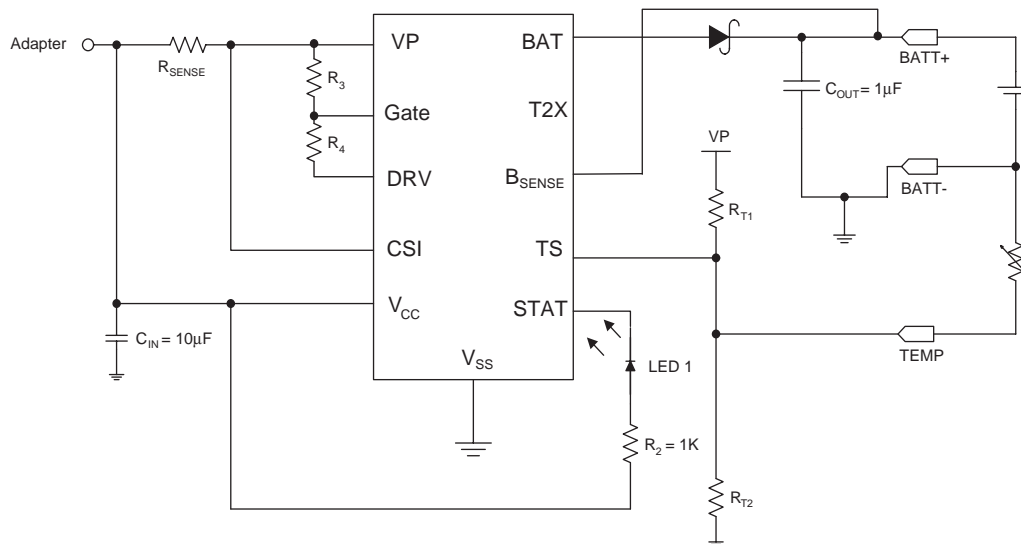

Pin Description

Pin #	Symbol	Function
1	TS	Battery temperature sense input.
2, 3, 8, 12	N/C	Not connected.
4	STAT	Battery charger status output. Connect an LED in series with 2.2kΩ from STAT to V _{IN} for a visual monitor battery charge state or connect to a microcontroller to monitor battery status. A 100kΩ resistor should be placed between STAT and V _{IN} for this function.
5	V _{SS}	Common ground connection.
6	DRV	Battery charge control output.
7	T2X	Battery trickle charge control input. Connect this pin to V _{SS} to double the battery trickle charge current. Leave this pin floating for normal trickle current (10% of full charge current). To enter microcontroller fast-read status, pull this pin high during power up.
9	BAT	Battery charge control output. Current regulated output to charge the battery. For best operation, a 0.1μF ceramic capacitor should be placed between BAT and GND.
10	V _{SS}	Common ground connection.
11	Gate	Input voltage for biasing the pass device.
13	V _P	Battery charge power input.
14	CSI	Current sense input.
15	B _{SENSE}	Battery voltage sense input.
16	V _{CC}	AAT3682 bias input power.
EP		Exposed paddle (bottom); connect to GND directly beneath the package.

Pin Configuration

**QFN44-16
(Top View)**

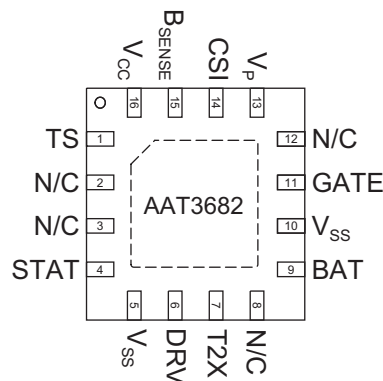

Absolute Maximum Ratings¹

Symbol	Description	Value	Units
V_{IN}	V_{IN} Relative to GND	-0.3 to 6.0	V
V_{CSI}	CSI to GND	-0.3 to $V_{CC}+0.3$	V
V_{T2X}	T2X to GND	-0.3 to 5.5	V
Bias, V_{BAT}	BAT to GND	-0.3 to $V_{CC}+0.3$	V
T_J	Operating Junction Temperature Range	-40 to 85	°C

Note 1: Stresses above those listed in Absolute Maximum Ratings may cause permanent damage to the device. Functional operation at conditions other than the operating conditions specified is not implied. Only one Absolute Maximum Rating should be applied at any one time.

Thermal Information

Symbol	Description	Value	Units
θ_{JA}	Maximum Thermal Resistance ^{1,2}	50	°C/W
P_D	Power Dissipation ($T_A = 25^\circ\text{C}$)	2.0	W

Notes:

1. Mounted on an FR4 board.
2. Derate 20mW/°C above 25°C.

Electrical Characteristics¹

$V_{IN} = 5.0V$, $T_A = -20$ to $70^\circ C$, unless otherwise noted. Typical values are at $T_A = 25^\circ C$.

Symbol	Description	Conditions	Min	Typ	Max	Units	
V_{IN}	Operation Input Voltage		4.7		6.0	V	
I_{CC}	Operating Current	$V_{IN} = 5.5V$, $V_{CH} = 4.2$		0.5	3.0	mA	
I_{SLEEP}	Sleep Mode Current	$V_{IN} = 3.5V$, $V_{CH} = 4.2$		3.0	6.0	μA	
$I_{STAT(HI)}$	STAT High Level Output Leakage Current	$V_{IN} = 5.5V$	-1.0		+1.0	μA	
$V_{STAT(LOW)}$	STAT Low Level Sink Current	$V_{IN} = 5.5V$, $I_{SINK} = 5mA$		0.3	0.6	V	
V_{CH}	Output Charge Voltage Regulation	$V_{BAT} = 4.2V$	$T_A = 25^\circ C$	4.175	4.20	4.225	V
			See Note 1	4.158	4.20	4.242	
V_{CS}	Charge Current Regulation	$V_{IN} = 5.5V$, $V_{CH} = 4.2$	90	100	110	mV	
I_{CH}	Charge Current	$V_{IN} = 5.5V$			650	mA	
V_{MIN}	Preconditioning Voltage Threshold	$V_{CH} = 4.2V$	3.04	3.1	3.16	V	
$V_{TRICKLE}$	Trickle Charge Current Regulation	T2X Floating; $V_{CH} = 4.2V$		10		mV	
T_{2X}	Trickle Charge Current Gain	$T_{2X} = V_{SS}$		1.8			
V_{TS1}	Low Temperature Threshold		29.1	30	30.9	$\%V_{CC}$	
V_{TS2}	High Temperature Threshold		58.2	60	61.8	$\%V_{CC}$	
V_{TERM}	Charge Termination Threshold Voltage		4	12	24	mV	
V_{RCH}	Battery Recharge Voltage Threshold	$V_{CH} = 4.2V$	4.018	4.1	4.182	V	
V_{UVLO}	Under-Voltage Lockout	V_{IN} Rising, $T_A = 25^\circ C$	3.5	4.0	4.5	V	
V_{OVP}	Over-Voltage Protection Threshold			4.4		V	
V_{OCP}	Over-Current Protection Threshold			200		$\%V_{CS}$	

Note 1. The AAT3682 output charge voltage is specified over $0^\circ C$ to $55^\circ C$ ambient temperature range; operation over $-20^\circ C$ to $70^\circ C$ is guaranteed by design.

Typical Characteristics

Battery Recharge Threshold Voltage vs. Temperature
 $R_{SENSE} = 0.15\Omega$

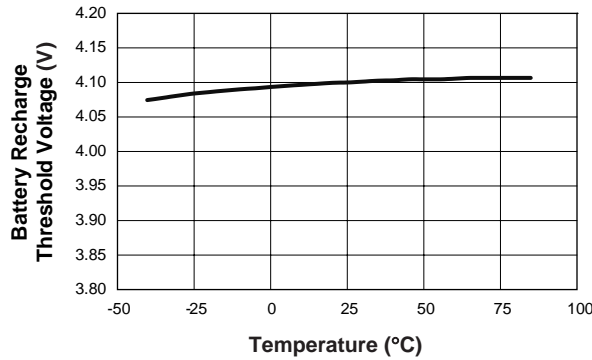

Regulated Output Voltage vs. Charge Current
 $R_{SENSE} = 0.15\Omega$

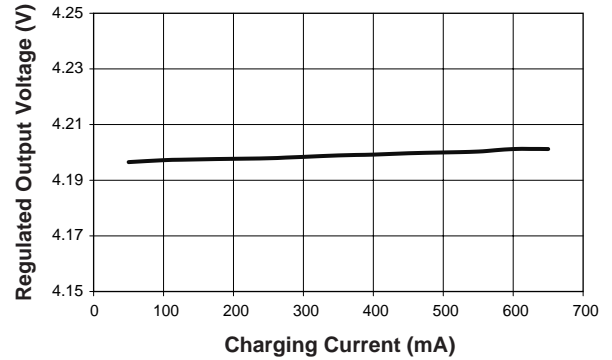

Regulated Output Voltage vs. Input Voltage
 $R_{SENSE} = 0.15\Omega$

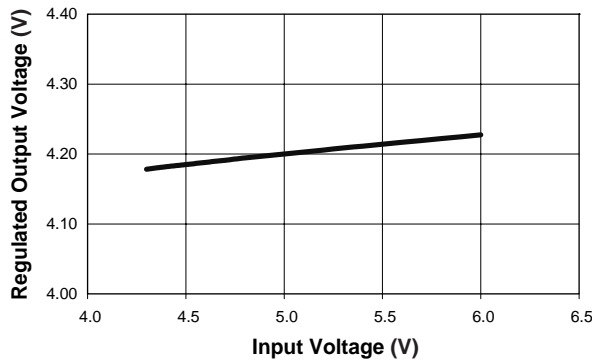

Regulated Output Voltage vs. Temperature
 $R_{SENSE} = 0.15\Omega$

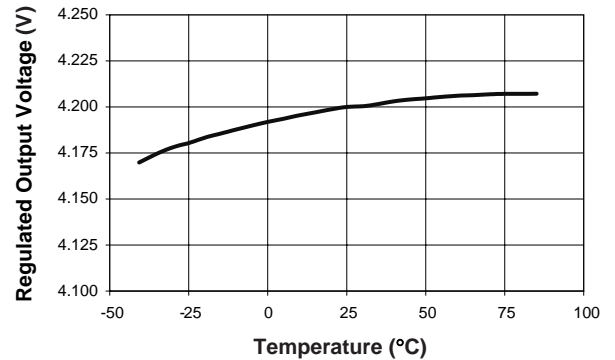

Trickle Charge Threshold Voltage vs. Temperature
 $R_{SENSE} = 0.15\Omega$

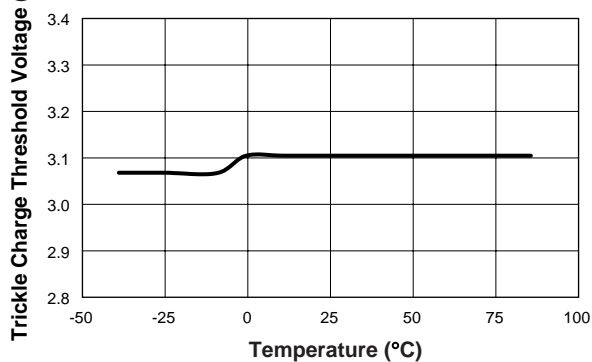

Trickle Charge Current vs. Temperature
 $R_{SENSE} = 0.15\Omega$

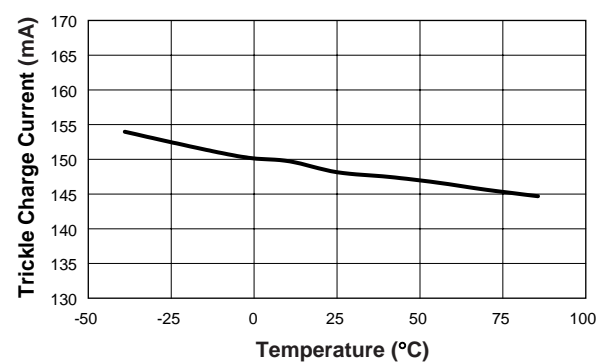

Typical Characteristics

Charging Current vs. Temperature
 $R_{SENSE} = 0.15\Omega$

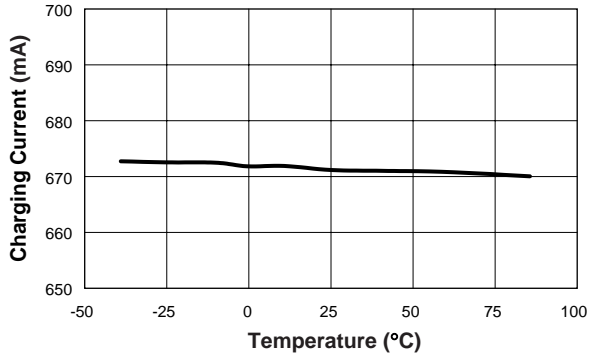

Charging Current vs. Input Voltage
 $R_{SENSE} = 0.15\Omega$ with External Schottky

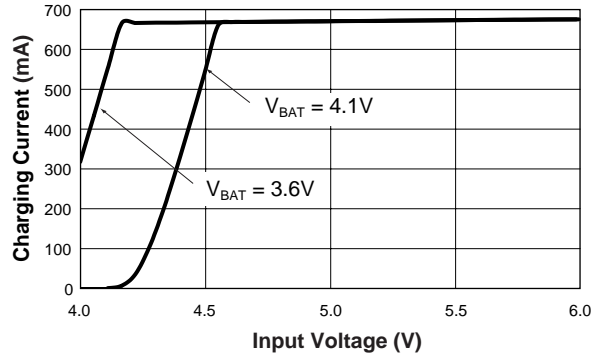

Charging Current vs. Battery Voltage
 $R_{SENSE} = 0.15\Omega$ with External Schottky

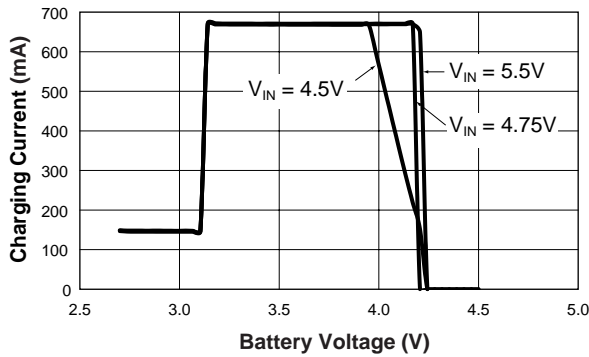

Trickle Charge Current vs. Input Voltage
 $R_{SENSE} = 0.15\Omega$ 1.8X Mode

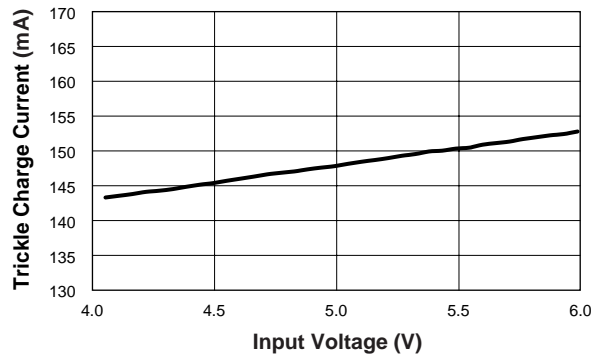

Typical Characteristics

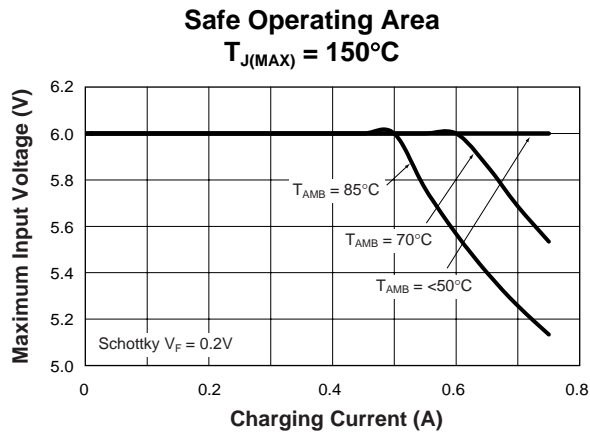
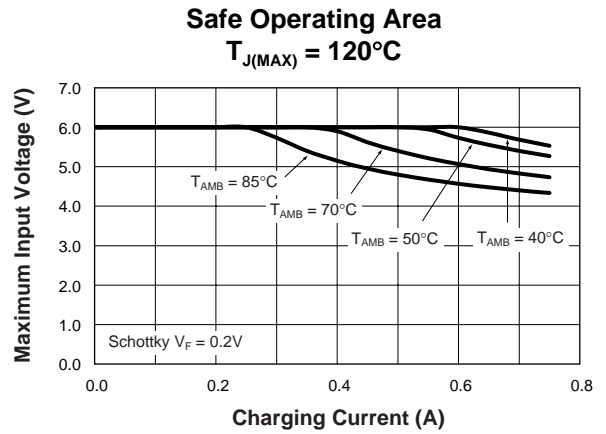
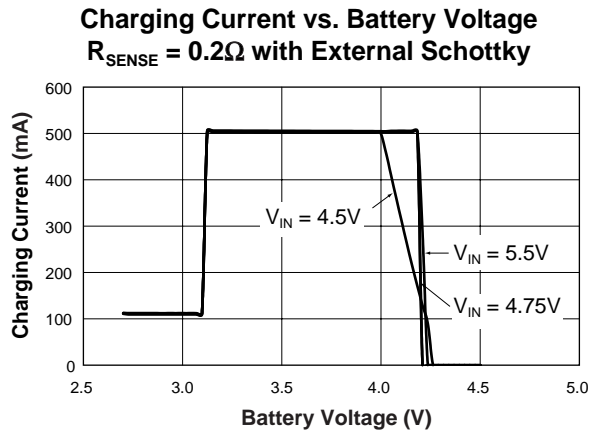
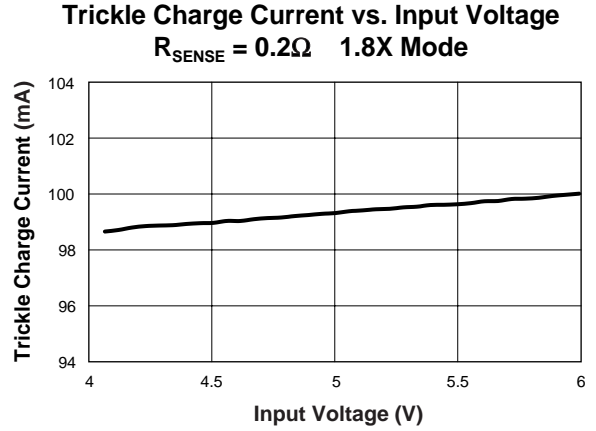
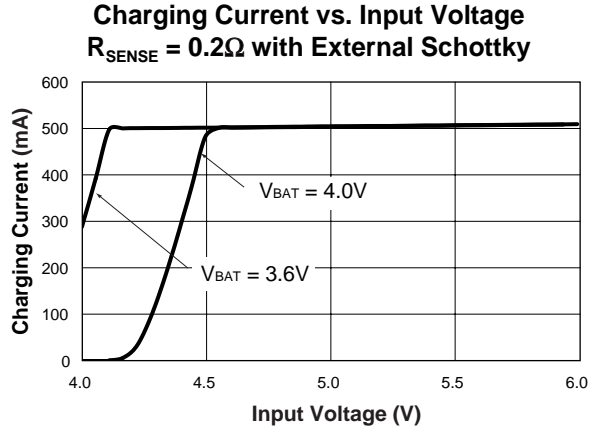

Functional Block Diagram

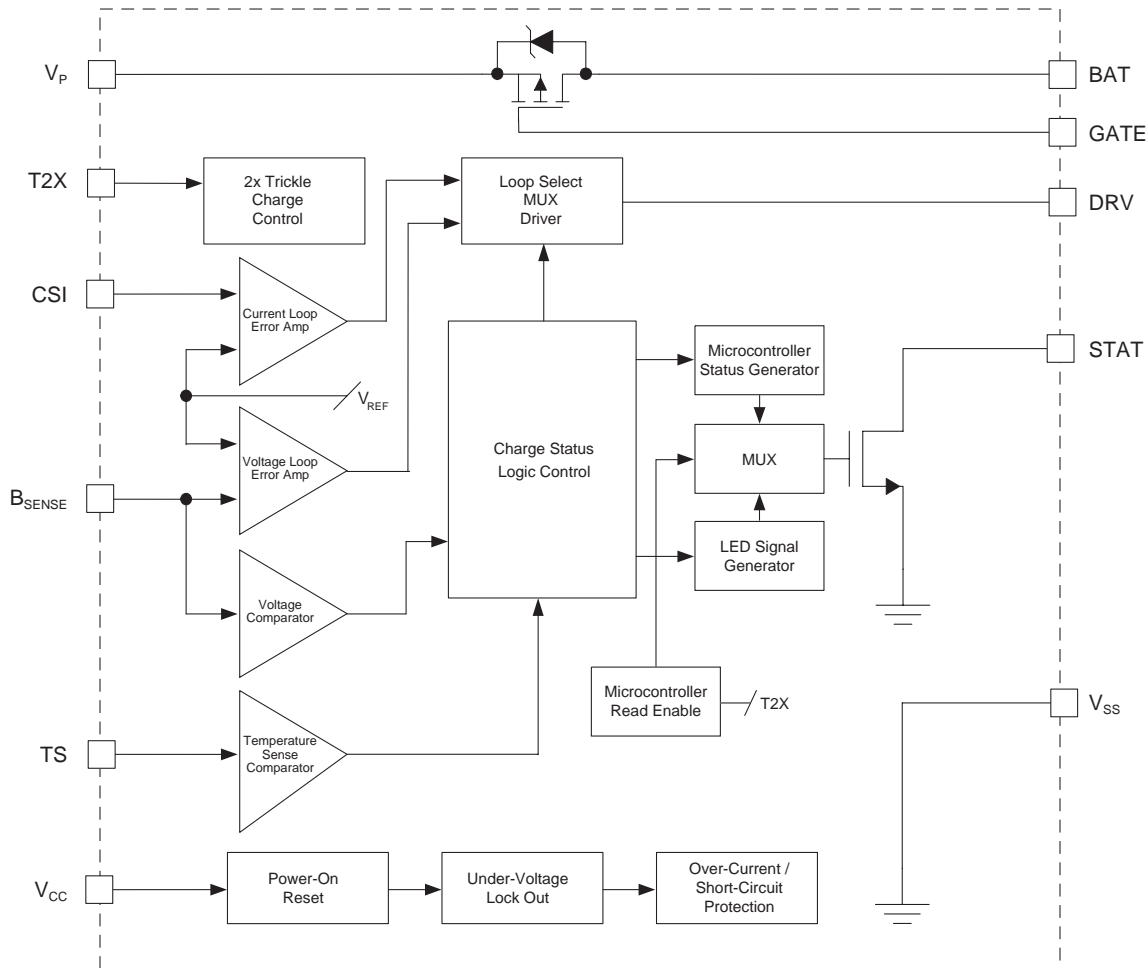

Functional Description

The AAT3682 is a linear charger designed for single cell Lithium-Ion or Lithium-Polymer batteries. It is a full-featured battery management system IC with multiple levels of power savings, system communication, and protection integrated inside. Refer to the block diagram and flow chart (Figure 1) in this section.

Cell Preconditioning

Before the start of charging, the AAT3682 checks several conditions in order to maintain a safe charging environment. The input supply must be above the minimum operating voltage, or under-voltage lockout threshold (V_{UVLO}), for the charging sequence to begin. Also, the cell temperature, as reported by a thermistor connected to the T_S pin, must be within the proper window for safe charging.

When these conditions have been met and a battery is connected to the BAT pin, the AAT3682 checks the state of the battery. If the cell voltage is below V_{MIN} , the AAT3682 begins preconditioning the cell. This is performed by charging the cell with 10% of the programmed constant-current amount. For example, if the programmed charge current is 500mA, then the preconditioning mode (trickle charge) current will be 50mA. Cell preconditioning is a safety precaution for deeply discharged cells

and, furthermore, limits power dissipation in the pass transistor when the voltage across the device is largest. The AAT3682 features an optional T2X mode, which allows faster trickle-charging at approximately two times the default rate. This mode is selected by connecting the T2X pin to V_{SS} . If an over-temperature fault is triggered, the fast trickle-charge will be latched off, and the AAT3682 will continue at the default 10% charge current.

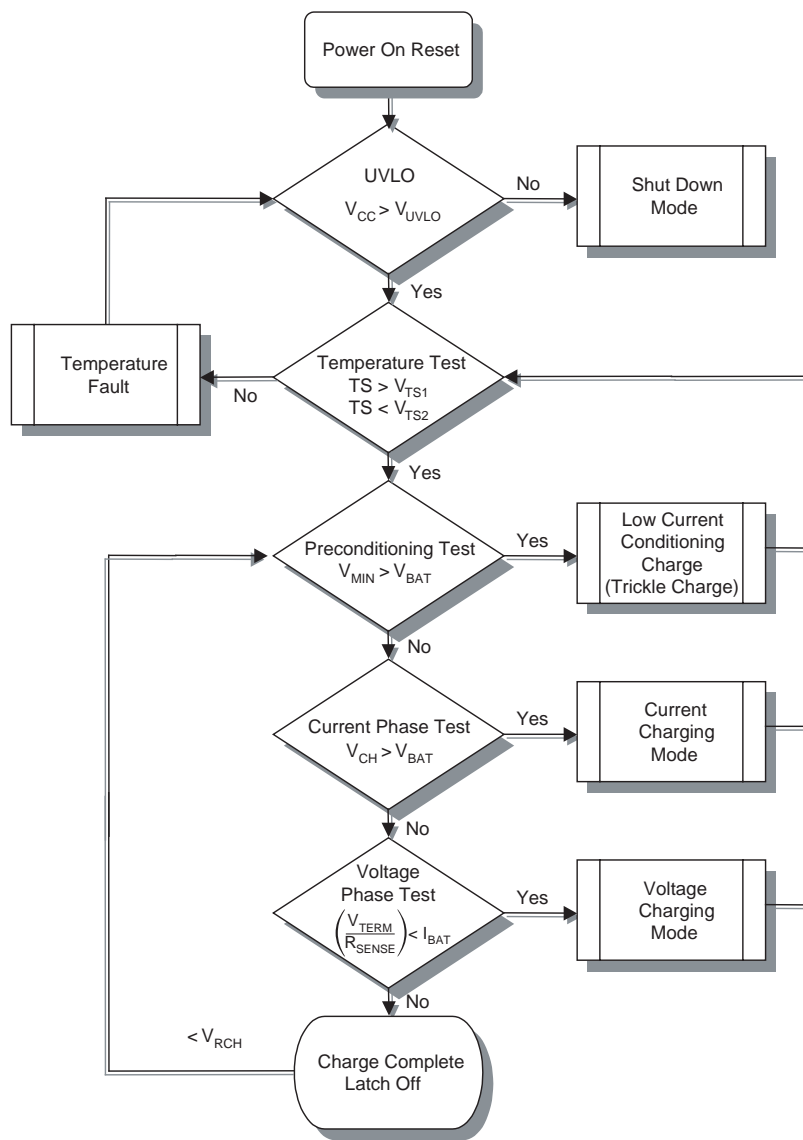

Figure 1: AAT3682 Operational Flow Chart.

Constant Current Charging

The cell preconditioning continues until the voltage on the BAT pin reaches V_{MIN} . At this point, the AAT3682 begins constant-current charging (fast charging). Current level for this mode is programmed using a current sense resistor R_{SENSE} between the V_{CC} and CSI pins. The CSI pin monitors the voltage across R_{SENSE} to provide feedback for the current control loop. The AAT3682 remains in constant current charge mode until the battery reaches the voltage regulation point, V_{CH} .

Constant Voltage Charging

When the battery voltage reaches V_{CH} during constant-current mode, the AAT3682 transitions to constant-voltage mode. The regulation voltage is factory programmed to 4.2V. In constant-voltage operation, the AAT3682 monitors the cell voltage and terminates the charging cycle when the voltage across R_{SENSE} decreases to approximately 10mV.

Charge Cycle Termination, Recharge Sequence

After the charge cycle is complete, the AAT3682 shuts off the pass device and automatically enters power-saving sleep mode. Either of two possible conditions will bring the IC out of sleep mode: the battery voltage at the BAT pin drops below V_{RCH} (recharge threshold voltage) or the AAT3682 is reset by cycling the input supply through the power-on sequence. Falling below V_{RCH} signals the IC that it is time to initiate a new charge cycle.

Sleep Mode

When the input supply is disconnected, the device automatically enters power-saving sleep mode. Only consuming an ultra-low 2 μ A current, the AAT3682 minimizes battery drain when it is not charging. This feature is particularly useful in applications where the input supply level may fall below the battery charge or under-voltage lockout level. In such cases, where the AAT3682 input voltage drops, the device will enter the sleep mode and automatically resume charging once the input supply has recovered from its fault condition. This makes the AAT3682 well suited for USB battery charger applications.

Charge Inhibit

The AAT3682 charging cycle is fully automatic; however, it is possible to stop the device from charging even when all conditions are met for proper charging. Switching the T_S pin to either V_{IN} or GND will force the AAT3682 to turn off the pass device and wait for a voltage between the low and high temperature voltage thresholds.

Resuming Charge and the V_{RCH} Threshold

The AAT3682 will automatically resume charging under most conditions when a battery charge cycle is interrupted. Events such as an input supply interruption or under voltage, removal and replacement of the battery under charge, or charging a partially drained battery are all possible. The AAT3682 will monitor the battery voltage and automatically resume charging in the appropriate mode based upon the measured battery cell voltage. This feature is useful for systems with an unstable input supply, which could be the case when powering a charger from a USB bus supply. It is also beneficial for charging or "topping off" partially discharged batteries. The only restriction on resuming charge of a battery is that the battery cell voltage must be below the battery recharge voltage threshold (V_{RCH}) specification. There is V_{RCH} threshold hysteresis built into the charge control system. This is done to prevent the charger from erroneously turning on and off once a battery charge cycle is complete.

For example, the AAT3682 has a typical V_{RCH} threshold of 4.1V. A battery under charge is above 4.1V, but is still in the constant voltage mode because it has not yet reached 4.2V to complete the charge cycle. If the battery is removed and then placed back on the charger, the charge cycle will not resume until the battery voltage drops below the V_{RCH} threshold. In another case, a battery under charge is in the constant current mode and the cell voltage is 3.7V when the input supply is inadvertently removed and then restored. The battery is below the V_{RCH} threshold and the charge cycle will immediately resume where it left off.

LED Display Charge Status Output

The AAT3682 provides a battery charge status output via the STAT pin. STAT is an open-drain serial

data output capable of displaying five distinct status functions with one LED connected between the STAT pin and V_p . There are four periods which determine a status word. Under default conditions, each output period is one second long; thus one status word will take four seconds to display through an LED. The five modes include:

1. Sleep/Charge Complete: The IC goes into Sleep mode when no battery is present -OR- when the charge cycle is complete.
2. Fault: When an Over-Current (OC) condition is detected by the current sense and control circuit -OR- when an Over-Voltage (OV) condition is detected at the BAT pin -OR- when a battery Over-Temperature fault is detected on the TEMP pin.
3. Battery Conditioning: When the charge system is in the 1X or 2X trickle charge mode.
4. Constant Current (CC) Mode: When the system is in the constant current charge mode.
5. Constant Voltage (CV) Mode: When the system is in the constant voltage charge mode.

An additional feature of the LED status display is for a Battery Not Detected state. When the AAT3682 senses there is no battery connected to the BAT pin, the STAT output will turn the LED on and off at a rate dependent on the size of the output capacitor being used. The LED cycles on for two periods then remains off for two periods. See Figure 2 below.

High-Speed Data Reporting

An optional system microcontroller interface can be enabled by pulling the T2X pin up to 4.5V to 5.5V during power-up sequence. The T2X pin should be pulled high with the use of a 100kΩ resistor. If the input supply to V_{IN} will not exceed 5.5V, then the T2X pin may be tied directly to V_{IN} through a 100KΩ resistor. Since this is a TTL level circuit, it may not be pulled higher than 5.5V without risk of damage to the device.

When the high-speed data report feature is enabled, the STAT output periods are sped up to 40μs, making the total status word 160μs in length. See Figure 3 below.

Charge Status	Output Status	LED Display			
		on/off	on/off	on/off	on/off
Sleep / Charge Complete	off / off / off / off	ON			
		OFF			
Temp., OC, OV Fault	on / on / off / off	ON			
		OFF			
Battery Conditioning	on / on / on / on	ON			
		OFF			
Constant Current Mode	on / on / on / off	ON			
		OFF			
Constant Voltage Mode	on / off / off / off	ON			
		OFF			

Figure 2: LED Display Output.

Charge Status	Output Status	STAT Level			
Sleep / Charge Complete	HI / HI / HI / HI				
Temp., OC, OV Fault	LO / LO / HI / HI				
Battery Conditioning	LO / LO / LO / LO				
Constant Current Mode	LO / LO / LO / HI				
Constant Voltage Mode	LO / HI / HI / HI				

Figure 3: Microcontroller Interface Logic Output.

An additional feature is the Output Status for the Battery Not Detected state. When the AAT3682 senses there is no battery connected to the BAT pin, the STAT pin cycles for two periods, then remains off for two periods. When in High-Speed Data Reporting, the AAT3682 will only trickle charge at the 2X trickle charge level. This is because the T2X pin is pulled high to enable the high-speed data reporting. A status display LED may not be connected to the STAT pin when the high-speed data reporting is being utilized. If both display modes are required, the display LED must be switched out of the circuit before the T2X pin is pulled high. Failing to do so could cause problems with the high-speed switching control circuits internal to the AAT3682.

Charge Complete LED Status Mode

A simplified LED status can be obtained by configuring the AAT3682 for high-speed data recording mode (T2X tied to V_{CC}) and installing a $0.047\mu\text{F}$ capacitor from the STAT pin to the V_{SS} pin (see Figure 4). In this configuration, the LED will be illuminated for all modes except the Sleep/Charge Complete mode. In addition, the T2X input must be tied to V_{CC} through a $100\text{k}\Omega$ resistor. In this mode, the trickle charge current will be 1.8X the normal trickle charge level. To reset the trickle charge current to the 1X level, the T_S input must be temporarily toggled low. Removing C3 forces the LED status to gradually dim out as the battery becomes fully charged (see Figure 5).

Protection Circuitry

The AAT3682 is a highly integrated battery management system IC including several protection features. In addition to battery temperature monitoring, the IC constantly monitors for over-current and over-voltage conditions; if an over-current situation occurs, the AAT3682 latches off the pass device to prevent damage to the battery or the system, and enters shutdown mode until the over-current event is terminated. An over-voltage condition is defined as a condition where the voltage on the BAT pin exceeds the maximum battery charge voltage. If an over-voltage condition occurs, the IC turns off the pass device until voltage on the BAT pin drops below the maximum battery charge constant voltage threshold. The AAT3682 will resume normal operation after the over-current or over-voltage condition is removed. During an over-current or over-voltage event, the STAT will report a FAULT signal. In the event of a battery over-temperature condition, the IC will turn off the pass device and report a FAULT signal on the STAT pin. After the system recovers from a temperature fault, the IC will resume operation in the 1X trickle charge mode to prevent damage to the system in the event a defective battery is placed under charge. Once the battery voltage rises above the trickle charge to constant current charge threshold, the IC will resume the constant current mode.

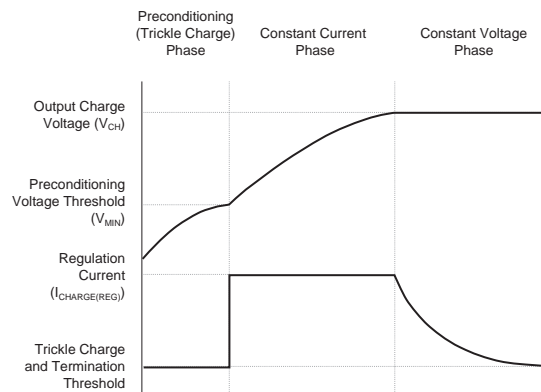

Figure 4: Typical Charge Profile.

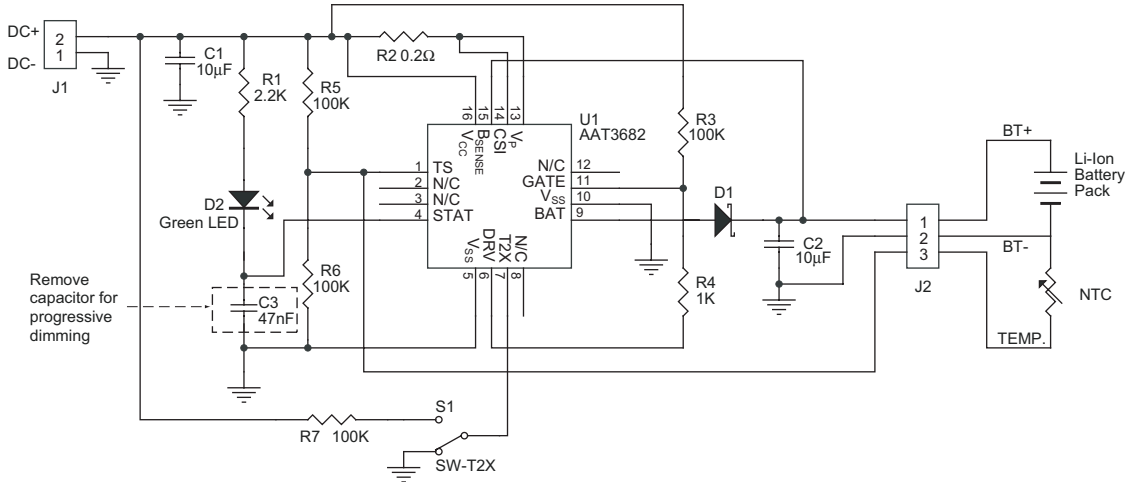

Figure 5: Evaluation Board Schematic.

Applications Information

Choosing a Sense Resistor

The charging rate recommended by Lithium-Ion cell vendors is normally 1C, with a 2C absolute maximum rating. Charging at the highest recommended rate offers the advantage of shortened charging time without decreasing the battery's lifespan. This means that the suggested fast charge rate for a 500mAH battery pack is 500mA. Refer to the Safe Operating Area curves in the Typical Characteristics section of this datasheet to determine the maximum allowable charge current for a given input voltage. The current sense resistor, R_{SENSE} , programs the charge current according to the following equation:

$$R_{SENSE} = \frac{V_{CC} - V_{CS1}}{I_{CHARGE}}$$

Where I_{CHARGE} is the desired typical charge current during constant-current charge mode. $V_{CC} - V_{CS1}$ is the voltage across R_{SENSE} , shown in the Electrical Characteristic table as V_{CS} . To program a nominal 500mA charge current during fast-charge, a 200mΩ value resistor should be selected. Calculate the worst case power dissipated in the sense resistor according to the following equation:

$$P = \frac{V_{CS}^2}{R_{SENSE}} = \frac{0.1V^2}{0.2\Omega} = 50mW$$

A 500mW LRC type sense resistor from IRC is adequate for this purpose. Higher value sense resistors can be used, decreasing the power dissipated in the sense resistor and pass transistor. The drawback of higher value sense resistors is that the charge cycle time is increased, so tradeoffs should be considered when optimizing the design.

Thermistor

The AAT3682 checks battery temperature before starting the charge cycle, as well as during all stages of charging. This is accomplished by monitoring the voltage at the T_S pin. Either a negative temperature coefficient thermistor (NTC) or positive-temperature coefficient thermistor (PTC) can be used because the AAT3682 checks to see that the voltage at T_S is within a voltage window bounded by V_{TS1} and V_{TS2} . Please see the following equations for specifying resistors:

R_{T1} and R_{T2} for use with **NTC** Thermistor

$$R_{T1} = \frac{5 \cdot R_{TH} \cdot R_{TC}}{3 \cdot (R_{TC} - R_{TH})}$$

$$R_{T2} = \frac{5 \cdot R_{TH} \cdot R_{TC}}{(2 \cdot R_{TC}) - (7 \cdot R_{TH})}$$

R_{T1} and R_{T2} for use with **PTC** Thermistor

$$R_{T1} = \frac{5 \cdot R_{TH} \cdot R_{TC}}{3 \cdot (R_{TC} - R_{TH})}$$

$$R_{T2} = \frac{5 \cdot R_{TH} \cdot R_{TC}}{(2 \cdot R_{TH}) - (7 \cdot R_{TC})}$$

Where R_{TC} is the thermistor's cold temperature resistance and R_{TH} is the thermistor's hot temperature resistance. See thermistor specifications for additional information. To ensure there is no dependence on the input supply changes, connect divider between V_{CC} and V_{SS} . Disabling the temperature-monitoring function is achieved by applying a voltage between V_{TS1} and V_{TS2} on the T_S pin.

Capacitor Selection

Input Capacitor

In general, it is good design practice to place a decoupling capacitor between the V_{CC} and V_{SS} pins. An input capacitor in the range of $1\mu\text{F}$ to $10\mu\text{F}$ is recommended. If the source supply is unregulated, it may be necessary to increase the capacitance to keep the input voltage above the under-voltage lockout threshold. If the AAT3682 is to be used in a system with an external power supply source, such as a typical AC-to-DC wall adaptor, then a C_{IN} capacitor in the range of $10\mu\text{F}$ should be used. A larger input capacitor in this application will minimize switching or power bounce effects when the power supply is "hot plugged" in.

Output Capacitor

The AAT3682 does not need an output capacitor for stability of the device itself. However, a capacitor connected between BAT and V_{SS} will control the output voltage when the AAT3682 is powered up when no battery is connected. The AAT3682 can become unstable if a high impedance load is placed across the BAT pin to V_{SS} . Such a case is possible with aging Li-Ion battery cells. As cells age through repeated charge and discharge cycles, the internal

impedance can rise over time. A $10\mu\text{F}$ or larger output capacitor will compensate for the adverse effects of a high impedance load and assure device stability over all operating conditions.

Power Dissipation

The voltage drop across the V_P and BAT pins multiplied times the charge current is used to determine the internal power dissipation. The maximum power dissipation occurs when the input voltage is at a maximum and the battery voltage is at the minimum preconditioning voltage threshold. This power is then multiplied times the package theta to determine the maximum junction temperature. The worst case power junction temperature is calculated as follows.

$$P_{MAX} = (V_{IN(MAX)} - V_{SENSE} - V_{SCHOTTKY} - V_{BAT(MIN)}) \cdot I_{CHG(MAX)}$$

$$= (5.5\text{V} - 0.1\text{V} - 0.2\text{V} - 3.04\text{V}) \cdot 550\text{mA}$$

$$= 1.2\text{W}$$

This equation can be used to determine the maximum input voltage given the maximum junction and ambient temperature and desired charge current.

$$V_{IN(MAX)} = \frac{T_{J(MAX)} - T_{AMB}}{\theta \cdot I_{CHG(MAX)}} + V_{BAT} + V_{SCHOTTKY} + V_{CS}$$

$$= \frac{120^\circ\text{C} - 70^\circ\text{C}}{50^\circ\text{C/W} \cdot 500\text{mA}} + 3.1\text{V} + 0.2\text{V} + 0.1\text{V}$$

$$= 5.3\text{V}$$

Operation Under No-Load

Under no-load conditions (i.e., when the AAT3682 is powered with no battery connected between the BAT pin and V_{SS}), the output capacitor is charged up very quickly by the trickle charge control circuit to the BAT pin until the output reaches the recharge threshold (V_{RCH}). At this point, the AAT3682 will drop into sleep mode. The output capacitor will discharge slowly by the capacitor's own internal leakage until the voltage seen at the BAT pin drops

below the V_{RCH} threshold. This 100mV cycle will continue at approximately 3Hz with a 0.1 μ F capacitor connected. A larger capacitor value will produce a slower voltage cycle. This operation mode can be observed by viewing the STAT LED blinking on and off at the rate established by the C_{OUT} value. For desktop charger applications, where it might not be desirable to have a "charger ready" blinking LED, a large C_{OUT} capacitor in the range of 100 μ F or more would prevent the operation of this mode.

Reverse Current Blocking Diode

A reverse-blocking diode is generally required for the circuit shown in Figure 5.

The blocking diode gives the system protection from a shorted input. If there is no other protection in the system, a shorted input could discharge the battery through the body diode of the internal pass MOSFET. If a reverse-blocking diode is added to the system, a device should be chosen that can withstand the maximum constant-current charge current at the maximum system ambient temperature.

Additionally, the blocking diode will prevent the battery from being discharged to the UVLO level by the AAT3682 in the event that power is removed from the input to the AAT3682. For this reason, the blocking diode must be placed in the location shown in Figure 5.

Diode Selection

Typically, a Schottky diode is used in reverse current blocking applications with the AAT3682. Other lower cost rectifier type diodes may also be used to save cost if sufficient input power supply head room is available.

The blocking diode selection should be based on merits of the device forward voltage (V_F), current rating, input supply level versus the maximum battery charge voltage, and cost.

First, one must determine the appropriate minimum diode forward voltage drop. Refer to the following equation:

$$V_{IN(MIN)} = V_{BAT(MAX)} + V_{F(TRAN)} + V_{F(DIODE)}$$

Where:

$V_{IN(MIN)}$ = Minimum input supply level

$V_{BAT(MAX)}$ = Maximum battery charge voltage required

$V_{F(TRAN)}$ = Pass transistor forward voltage drop

$V_{F(DIODE)}$ = Blocking diode forward voltage

Based on the maximum constant current charge level set for the system, the next step is to determine the minimum current rating and power handling capacity for the blocking diode. The constant current charge level itself will dictate what the minimum current rating must be for a given blocking diode. The minimum power handling capacity must be calculated based on the constant current amplitude and the diode forward voltage (V_F):

$$P_{D(MIN)} = V_F I_{CC}$$

Where:

$P_{D(MIN)}$ = Minimum power rating for a diode selection

V_F = Diode forward voltage

I_{CC} = Constant current charge level for the system

Schottky Diodes

Schottky diodes are selected for this application because they have a low forward voltage drop, typically between 0.3V and 0.4V. A lower V_F permits a lower voltage drop at the constant current charge level set by the system; less power will be dissipated in this element of the circuit. A Schottky diode allows for lower power dissipation, smaller component package sizes, and greater circuit layout densities.

Rectifier Diodes

Any general purpose rectifier diode can be used with the AAT3682 application circuit in place of a higher cost Schottky diode. The design trade-off is that a rectifier diode has a high forward voltage drop. V_F for a typical silicon rectifier diode is in the range of 0.7V. A higher V_F will place an input supply voltage requirement for the battery charger system. This will also require a higher power rated diode since the voltage drop at the constant current charge amplitude will be greater. Refer to the previously stated equations to calculate the minimum V_{IN} and diode P_D for a given application.

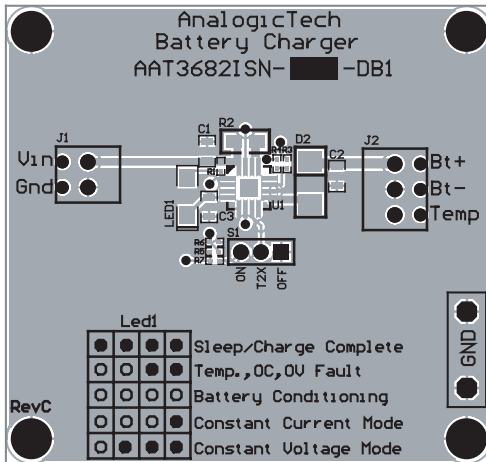

Figure 6: Evaluation Board Top Side Layout.

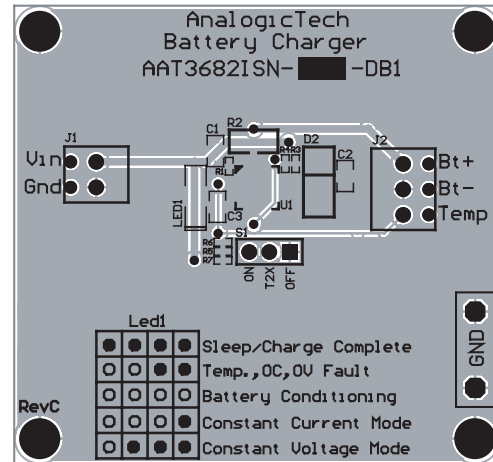

Figure 7: Evaluation Board Bottom Side Layout.

Reference

Component Designator	Description	Footprint	Part Number	Manufacturer
U1	Battery Charger AAT3682	QFN44-16	AAT3682-4.2	AnalogicTech
C1	Ceramic Capacitor 10μF-10V-X5R	0805	GRM21BR61A106KE19L	muRata
C2	Ceramic Capacitor 10μF-10V-X5R	0805	GRM21BR61A106KE19L	muRata
C3	Ceramic Capacitor 0.047μF-10V-X7R	0805	VJ0805Y473KXQA	Vishay
R1	Resistor 2.2KΩ 1/4W	0402	CRCW04022211F	Vishay
R2	Current Sensing Resistor 0.2Ω 1/4W	0805	RL1220S-R20-F	SSM Susumu
R3	Resistor 100KΩ 1% 1/4W	0402	CRCW04021003F	Vishay
R4	Resistor 1KΩ 1% 1/4W	0402	CRCW04021001F	Vishay
R5	Resistor 100KΩ 1% 1/4W	0402	CRCW04021003F	Vishay
R6	Resistor 100KΩ 1% 1/4W	0402	CRCW04021003F	Vishay
R7	Resistor 100KΩ 1% 1/4W	0402	CRCW04021003F	Vishay
J1	4-Pin Socket Connector	4 Pin	277-1273-ND	
J2	6-Pin Socket Connector	6 Pin	277-1274-ND	
S1	Jumper Stand Switch	2 mm Jumper	S2105-40-ND	
D1	Green LED	1206	L62215CT-ND	Chicago Miniature
D2	3.0A Schottky Diode	SMA	B340LADITR-ND	Diodes Incorporated

Ordering Information

Output Voltage	Package	Marking	Part Number (Tape and Reel)
4.2V	QFN44-16	MGXXY	AAT3682ISN-4.2-T1

Note: Sample stock is generally held on part numbers listed in **BOLD**.
 Note 1: XYY = assembly and date code.

Package Information

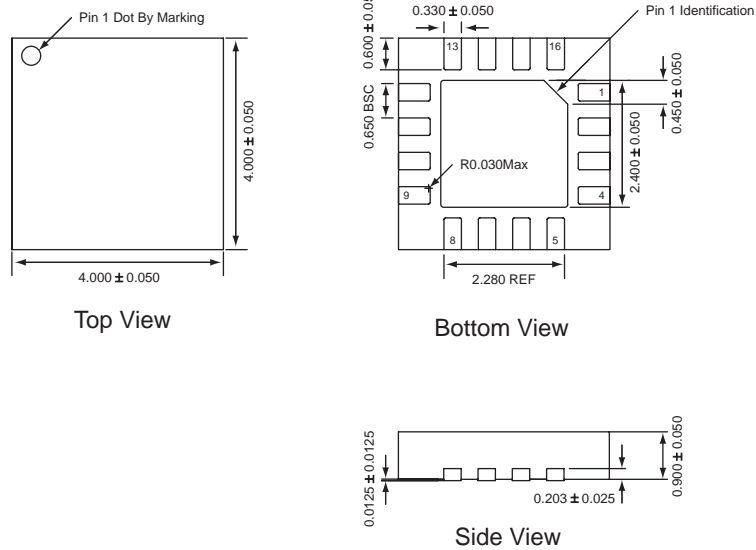

All dimensions in millimeters.

AnalogicTech cannot assume responsibility for use of any circuitry other than circuitry entirely embodied in an AnalogicTech product. No circuit patent licenses, copyrights, mask work rights, or other intellectual property rights are implied.

AnalogicTech reserves the right to make changes to their products or specifications or to discontinue any product or service without notice, and advise customers to obtain the latest version of relevant information to verify, before placing orders, that information being relied on is current and complete. All products are sold subject to the terms and conditions of sale supplied at the time of order acknowledgement, including those pertaining to warranty, patent infringement, and limitation of liability.

AnalogicTech warrants performance of its semiconductor products to the specifications applicable at the time of sale in accordance with AnalogicTech's standard warranty. Testing and other quality control techniques are utilized to the extent AnalogicTech deems necessary to support this warranty. Specific testing of all parameters of each device is not necessarily performed.

Advanced Analogic Technologies, Inc.
830 E. Arques Avenue, Sunnyvale, CA 94085
Phone (408) 737-4600
Fax (408) 737-4611

This datasheet has been download from:

www.datasheetcatalog.com

Datasheets for electronics components.